

DATA SHEET

SAA3049A

Infrared remote control decoder

Product specification
Supersedes data of 1996 Apr 15
File under Integrated Circuits, IC02

1996 Sep 13

Infrared remote control decoder

SAA3049A

FEATURES

- Decodes 64 remote control commands with a maximum of 32 subaddresses
- Accepts RECS80 codes with pulse position modulation (SAA3004, SAA3007, SAA3008) or RC5 codes with bi-phase transmission (SAA3006, SAA3010)
- Suitable for low voltage and low SAA3049A supply current applications
- Adding circuitry for binary decoding allows a maximum of 2048 commands to be used, for example 1-of-16 decoder (HEF4515).

GENERAL DESCRIPTION

The main function of the SAA3049A is to check and convert the received coded data (RECS80/RC5) into latched binary outputs. The device address can be hard-wired for a particular address, allowing several devices in one location. Alternatively, received data with any address can be accepted; the received data and address are then outputs.

ORDERING INFORMATION

TYPE NUMBER	PACKAGE		
	NAME	DESCRIPTION	VERSION
SAA3049AP	DIP20	plastic dual in-line package; 20 leads (300 mil)	SOT146-1
SAA3049AT	SO20	plastic small outline package; 20 leads; body width 7.5 mm	SOT163-1

Infrared remote control decoder

SAA3049A

SYSTEM DIAGRAM

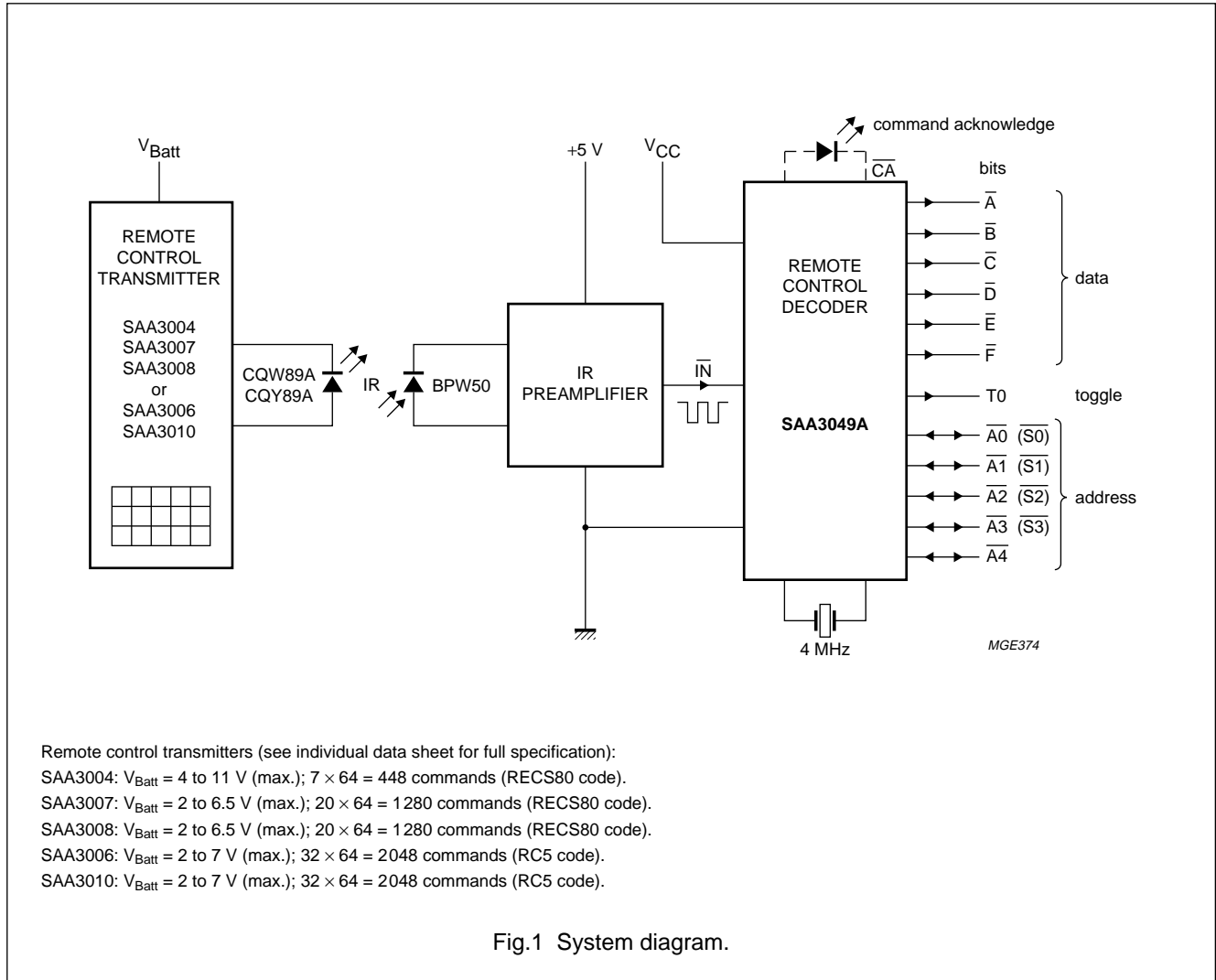

Infrared remote control decoder

SAA3049A

PINNING

SYMBOL	PIN	DESCRIPTION
\bar{A}	1	data output
\bar{B}	2	data output
\bar{C}	3	data output
\bar{D}	4	data output
\bar{E}	5	data output
\bar{F}	6	data output
$\bar{A0} (\bar{S0})$	7	data/address output/input
$\bar{A1} (\bar{S1})$	8	data/address output/input
\bar{IN}	9	digital input
GND	10	ground
MODE	11	RC5/RECS80 mode selection
XTAL1	12	crystal oscillator
XTAL2	13	crystal oscillator
RESET	14	reset input
$\bar{A4}$	15	address output/input
$\bar{A3} (\bar{S3})$	16	address output/input
$\bar{A2} (\bar{S2})$	17	address output/input
T0	18	T0 bit
CRI	19	command received indicator
V _{CC}	20	supply voltage

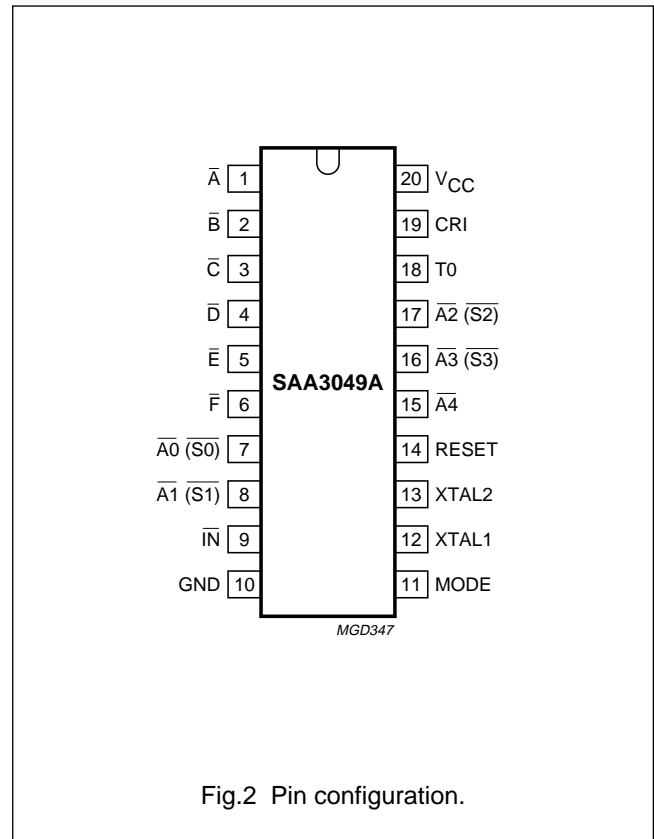

Fig.2 Pin configuration.

Infrared remote control decoder

SAA3049A

LIMITING VALUES

In accordance with the Absolute Maximum Rating System (IEC 134).

SYMBOL	PARAMETER	CONDITIONS	MIN.	MAX.	UNIT
V_{CC}	supply voltage		-0.5	+7	V
V_I	input voltage	any pin	-0.5	$V_{CC} + 0.5$	V
I_I	DC input current	any pin	-	-10	mA
I_O	DC output current	any pin	-	10	mA
P_{tot}	total power dissipation		-	125	mW
P_o	power dissipation per output		-	30	mW
I_{DD}	positive supply current		-50	+50	mA
I_{SS}	negative supply current		-100	+50	mA
T_{amb}	operating ambient temperature		-40	+85	°C
T_{stg}	storage temperature		-65	+150	°C

HANDLING

Inputs and outputs are protected against electrostatic charge in normal handling. However, to be totally safe, it is desirable to take normal precautions appropriate to handling MOS devices (see *"Handling MOS Devices"*).

Infrared remote control decoder

SAA3049A

CHARACTERISTICS $V_{CC} = 2.5$ to 5.5 V; $T_{amb} = -40$ to $+85$ °C; unless otherwise specified.

SYMBOL	PARAMETER	CONDITIONS	MIN.	TYP.	MAX.	UNIT
Supply						
V_{CC}	supply voltage		2.5	–	5.5	V
I_{CC}	supply current	$V_{DD} = 3$ V, $f_{xtal} = 4$ MHz	–	0.3	0.7	mA
Input signals (pin 9)						
V_{IH}	HIGH level input voltage		$0.7V_{CC}$	–	V_{CC}	V
V_{IL}	LOW level input voltage		0	–	$0.3V_{CC}$	V
Mode selection (pin 11)						
V_{IH}	HIGH level input voltage		$0.7V_{CC}$	–	V_{CC}	V
V_{IL}	LOW level input voltage		0	–	$0.3V_{CC}$	V
Command received indicator and mode control (pin 19); note 1						
V_{IH}	HIGH level input voltage		$0.7V_{CC}$	–	V_{CC}	V
V_{IL}	LOW level input voltage		0	–	$0.3V_{CC}$	V
Crystal oscillator						
f_{osc}	oscillator frequency	note 2	–	4	–	MHz
Outputs						
OPEN-DRAIN WITHOUT INTERNAL PULL-UP RESISTOR; note 3						
$I_{OL(sink)}$	LOW level output sink current	$V_{CC} = 5$ V; $V_{OL} = 0.4$ V	–1.6	–12	–	mA

Notes

- With pin 19 = HIGH, then pins 7, 8, 15, 16 and 17 are address inputs.
With pin 19 = LOW, then pins 7, 8, 15, 16, and 17 are 4 or 5 address received outputs.
 - In Figs 5, 6 and 7 this HIGH/LOW switching is dependent on whether the transistor on pin 19 is fed via a series resistor or not. In both applications pin 19, which toggles several times (see Fig.4) while a valid command is acknowledged, can be used to activate (flash) an LED indicator.
- A quartz crystal with a frequency of 4 MHz is recommended for the standard transmitter application.
- Application as output requires connection of an external pull-up resistor.

Infrared remote control decoder

SAA3049A

Reset

The circuit is shown in Figs 5, 6 and 7. The alternative reset circuit shown in Fig.3 protects against short term power supply transients by generating a reset.

The reset pin should either be connected to external reset circuitry as proposed or connected to V_{SS} . If connected to V_{SS} , a reset pulse will be generated by the on-chip Power-on reset circuit at typically 1.3 V (± 500 mV accuracy).

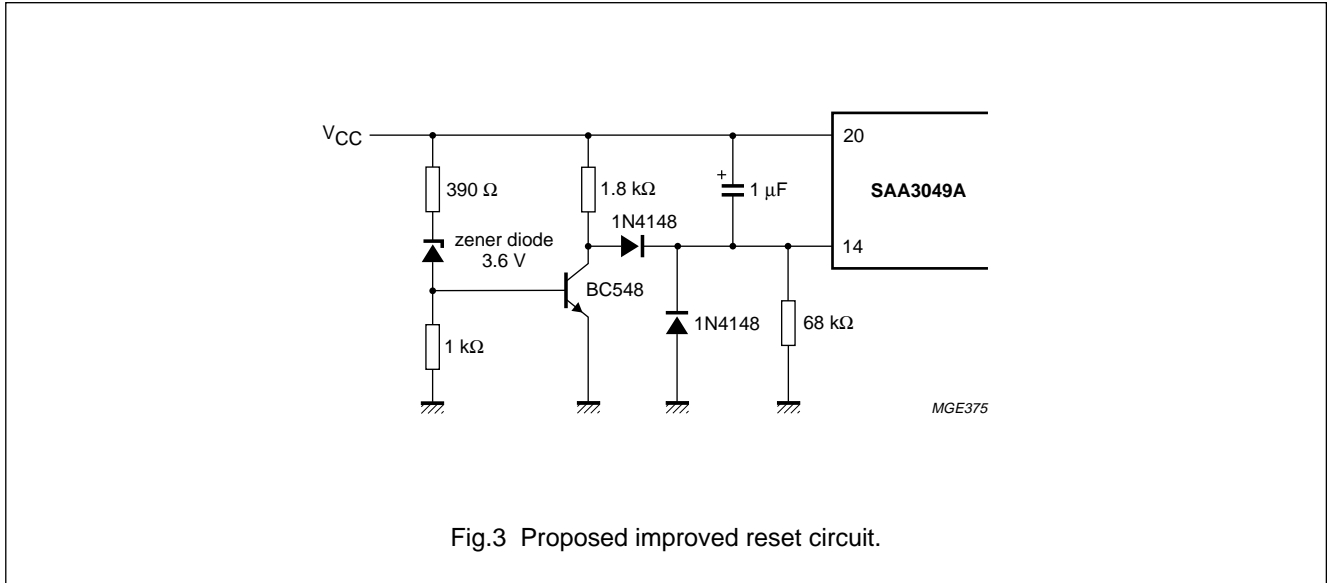

Fig.3 Proposed improved reset circuit.

Infrared signal input (pin 9)

This pin is sensitive to a negative-going edge.

Command received indicator (pin 19)

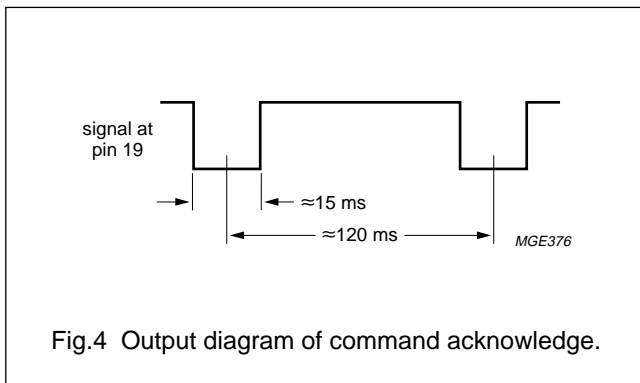

Fig.4 Output diagram of command acknowledge.

APPLICATION INFORMATION

In Fig.5, the circuit shown is for use with transmitters SAA3004, SAA3007 or SAA3008; pin 11 is HIGH for RECS80 code.

In Fig.6, the circuit shown is for use with transmitter types SAA3006 or SAA3010; pin 11 is LOW for RC5 code.

In Fig.7, the decoder is set for the required subaddress by holding the address pins HIGH or LOW. Pin 11 is HIGH for use with transmitter types SAA3004, SAA3007 or SAA3008 (RECS80 code). Pin 11 is LOW for use with transmitter types SAA3006 or SAA3010 (RC5 code). The remote control decoder is for up to 32 subaddresses with 6 + 1-bit parallel outputs (RC5 code).

Infrared remote control decoder

SAA3049A

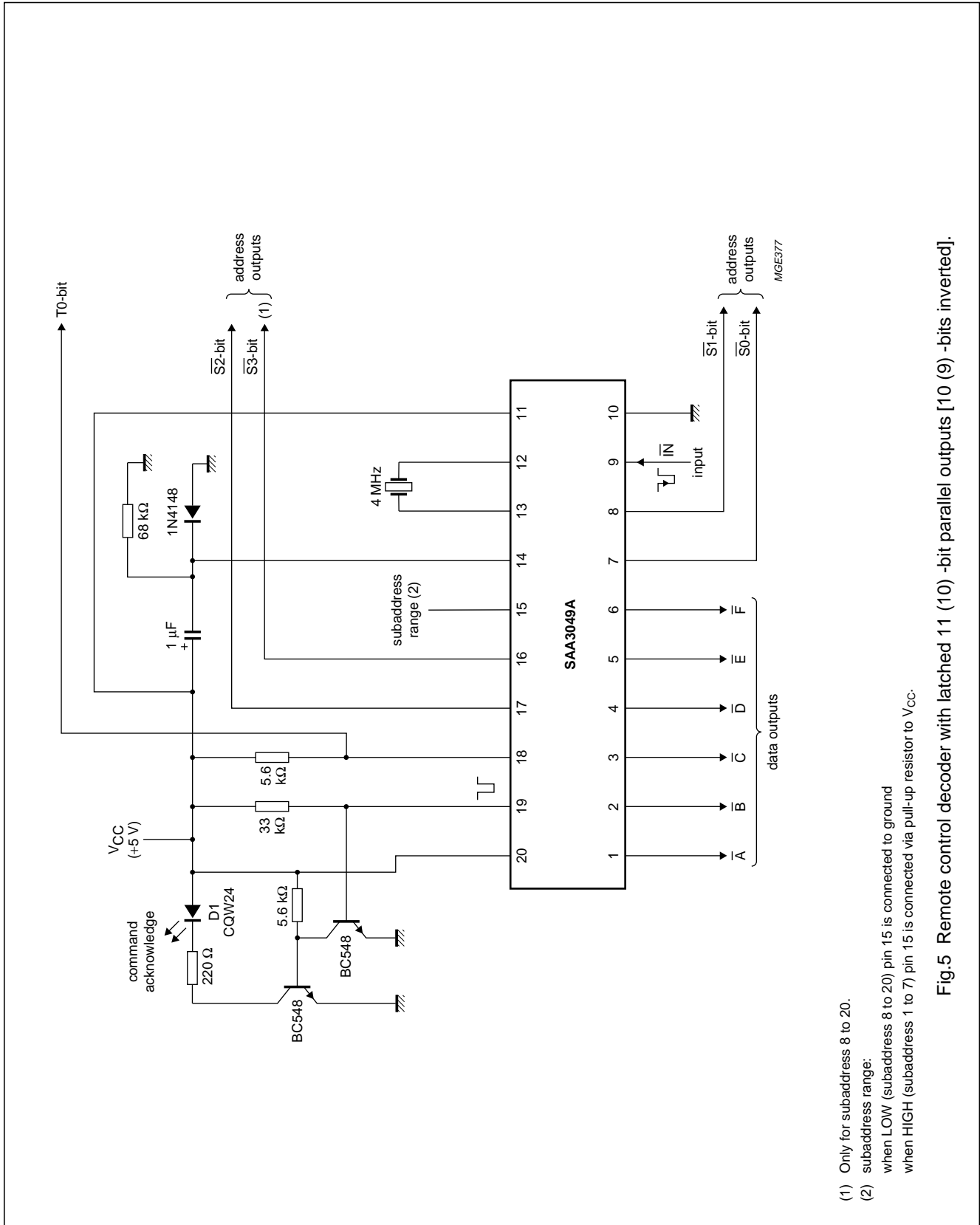

- (1) Only for subaddress 8 to 20.
- (2) subaddress range:
 when LOW (subaddress 8 to 20) pin 15 is connected to ground
 when HIGH (subaddress 1 to 7) pin 15 is connected via pull-up resistor to V_{CC}.

Fig.5 Remote control decoder with latched 11 (10) -bit parallel outputs [10 (9) -bits inverted].

Infrared remote control decoder

SAA3049A

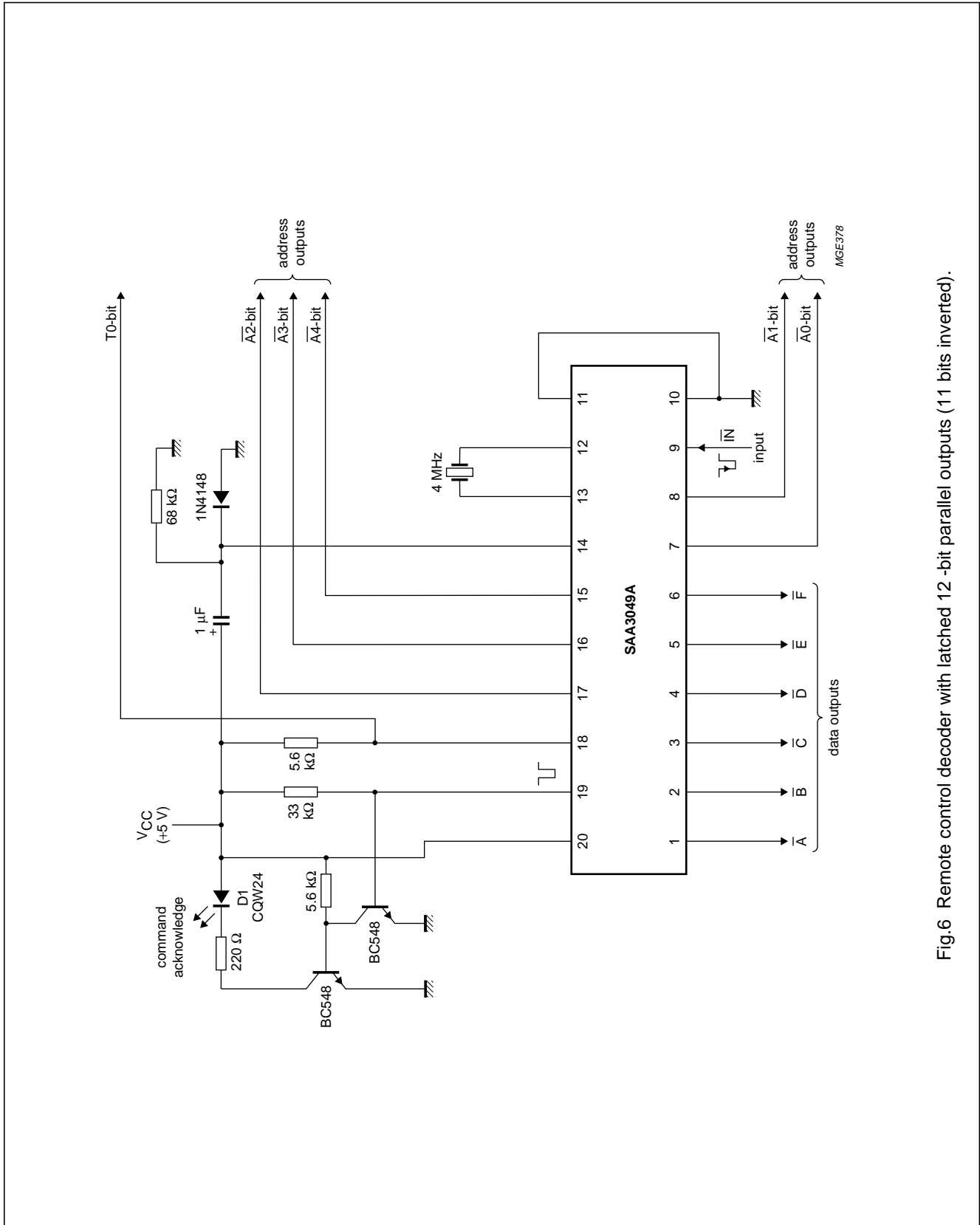

Fig.6 Remote control decoder with latched 12-bit parallel outputs (11 bits inverted).

Infrared remote control decoder

SAA3049A

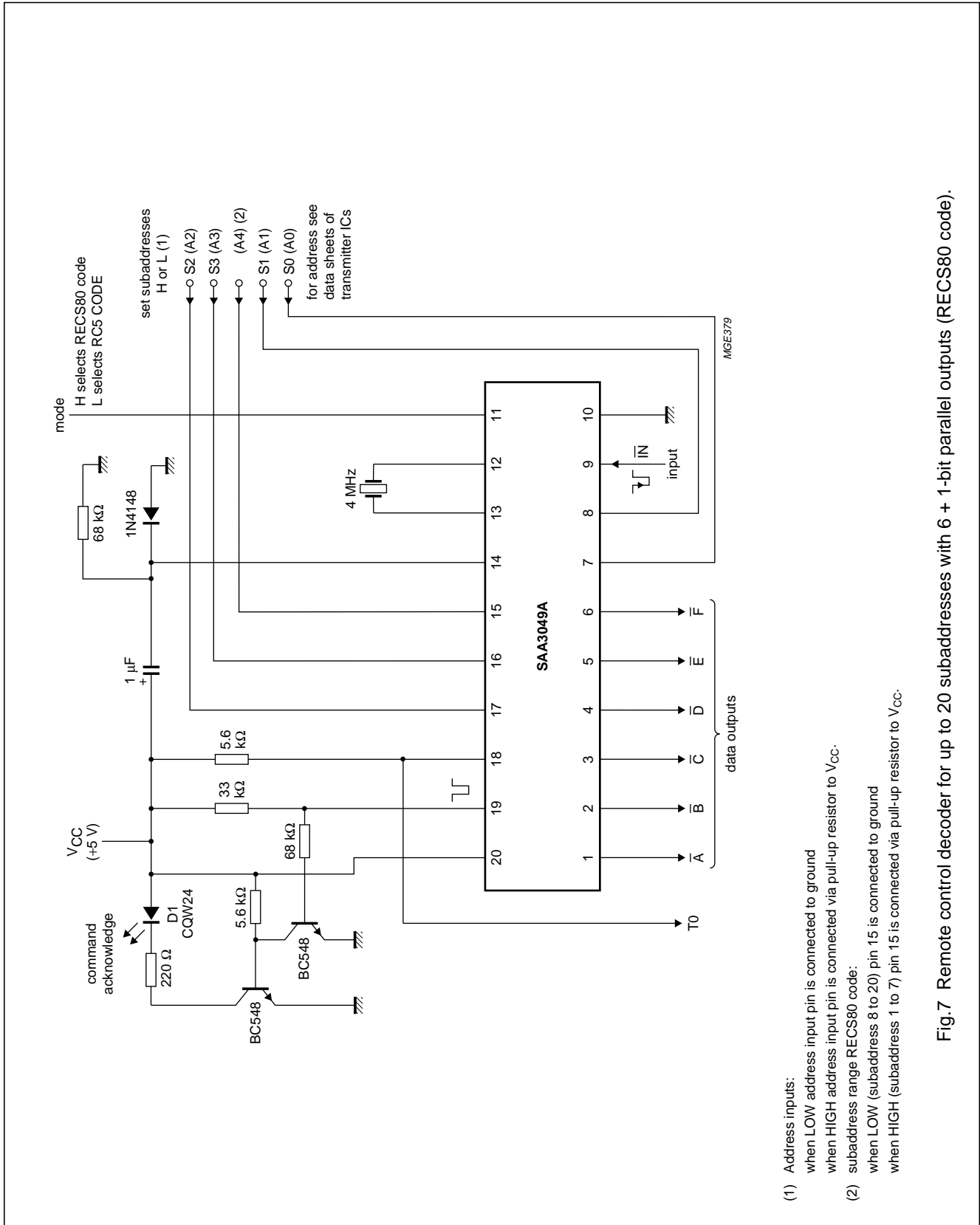

Fig.7 Remote control decoder for up to 20 subaddresses with 6 + 1-bit parallel outputs (RECS80 code).

- (1) Address inputs:
 - when LOW address input pin is connected to ground
 - when HIGH address input pin is connected via pull-up resistor to V_{CC}.
- (2) subaddress range RECS80 code:
 - when LOW (subaddress 8 to 20) pin 15 is connected to ground
 - when HIGH (subaddress 1 to 7) pin 15 is connected via pull-up resistor to V_{CC}.

Infrared remote control decoder

SAA3049A

PACKAGE OUTLINES

DIP20: plastic dual in-line package; 20 leads (300 mil)

SOT146-1

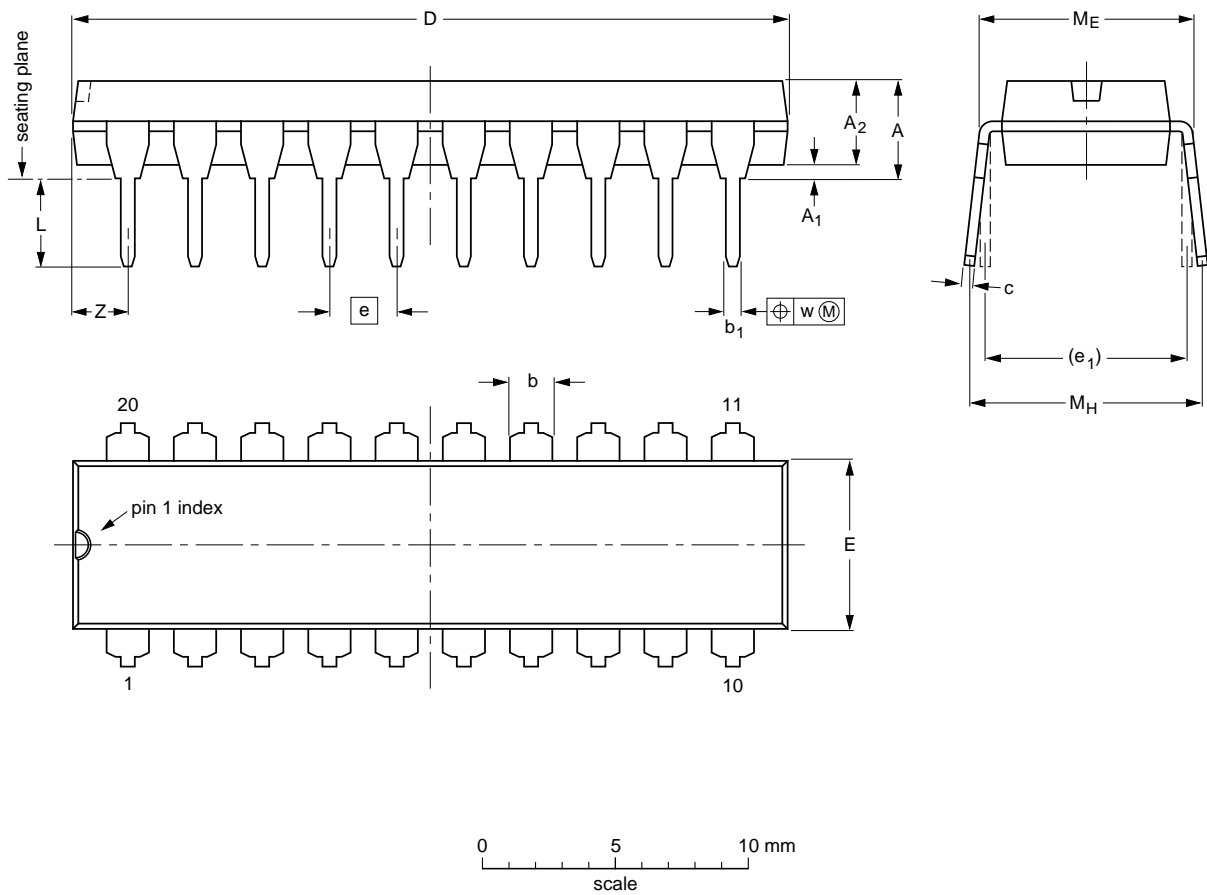

DIMENSIONS (inch dimensions are derived from the original mm dimensions)

UNIT	A max.	A ₁ min.	A ₂ max.	b	b ₁	c	D ⁽¹⁾	E ⁽¹⁾	e	e ₁	L	M _E	M _H	w	Z ⁽¹⁾ max.
mm	4.2	0.51	3.2	1.73 1.30	0.53 0.38	0.36 0.23	26.92 26.54	6.40 6.22	2.54	7.62	3.60 3.05	8.25 7.80	10.0 8.3	0.254	2.0
inches	0.17	0.020	0.13	0.068 0.051	0.021 0.015	0.014 0.009	1.060 1.045	0.25 0.24	0.10	0.30	0.14 0.12	0.32 0.31	0.39 0.33	0.01	0.078

Note

1. Plastic or metal protrusions of 0.25 mm maximum per side are not included.

OUTLINE VERSION	REFERENCES				EUROPEAN PROJECTION	ISSUE DATE
	IEC	JEDEC	EIAJ			
SOT146-1			SC603			92-11-17 95-05-24

Infrared remote control decoder

SAA3049A

SO20: plastic small outline package; 20 leads; body width 7.5 mm

SOT163-1

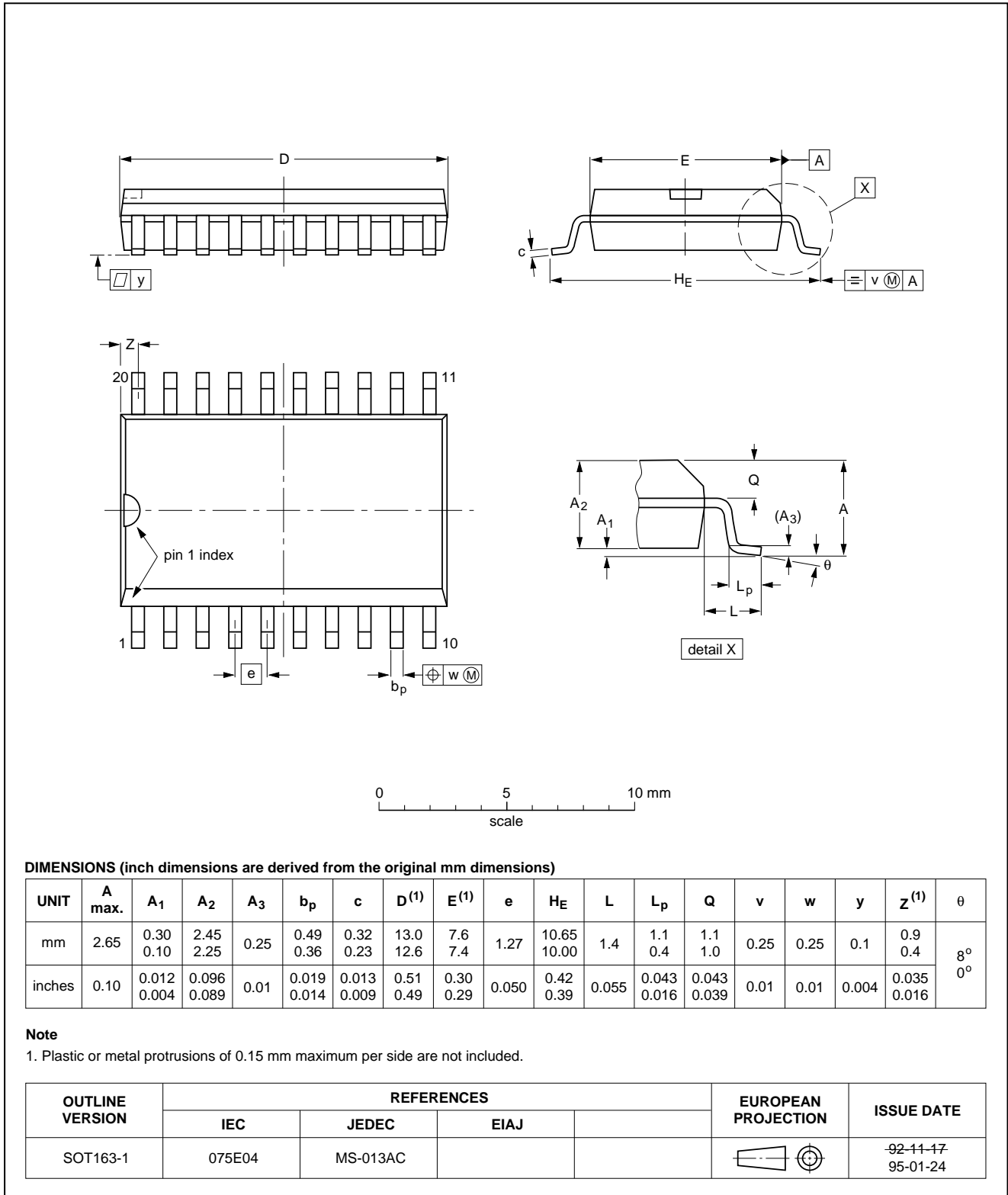

Infrared remote control decoder

SAA3049A

SOLDERING

Introduction

There is no soldering method that is ideal for all IC packages. Wave soldering is often preferred when through-hole and surface mounted components are mixed on one printed-circuit board. However, wave soldering is not always suitable for surface mounted ICs, or for printed-circuits with high population densities. In these situations reflow soldering is often used.

This text gives a very brief insight to a complex technology. A more in-depth account of soldering ICs can be found in our *"IC Package Databook"* (order code 9398 652 90011).

DIP

SOLDERING BY DIPPING OR BY WAVE

The maximum permissible temperature of the solder is 260 °C; solder at this temperature must not be in contact with the joint for more than 5 seconds. The total contact time of successive solder waves must not exceed 5 seconds.

The device may be mounted up to the seating plane, but the temperature of the plastic body must not exceed the specified maximum storage temperature ($T_{stg\ max}$). If the printed-circuit board has been pre-heated, forced cooling may be necessary immediately after soldering to keep the temperature within the permissible limit.

REPAIRING SOLDERED JOINTS

Apply a low voltage soldering iron (less than 24 V) to the lead(s) of the package, below the seating plane or not more than 2 mm above it. If the temperature of the soldering iron bit is less than 300 °C it may remain in contact for up to 10 seconds. If the bit temperature is between 300 and 400 °C, contact may be up to 5 seconds.

SO

REFLOW SOLDERING

Reflow soldering techniques are suitable for all SO packages.

Reflow soldering requires solder paste (a suspension of fine solder particles, flux and binding agent) to be applied to the printed-circuit board by screen printing, stencilling or pressure-syringe dispensing before package placement.

Several techniques exist for reflowing; for example, thermal conduction by heated belt.

Dwell times vary between 50 and 300 seconds depending on heating method. Typical reflow temperatures range from 215 to 250 °C.

Preheating is necessary to dry the paste and evaporate the binding agent. Preheating duration: 45 minutes at 45 °C.

WAVE SOLDERING

Wave soldering techniques can be used for all SO packages if the following conditions are observed:

- A double-wave (a turbulent wave with high upward pressure followed by a smooth laminar wave) soldering technique should be used.
- The longitudinal axis of the package footprint must be parallel to the solder flow.
- The package footprint must incorporate solder thieves at the downstream end.

During placement and before soldering, the package must be fixed with a droplet of adhesive. The adhesive can be applied by screen printing, pin transfer or syringe dispensing. The package can be soldered after the adhesive is cured.

Maximum permissible solder temperature is 260 °C, and maximum duration of package immersion in solder is 10 seconds, if cooled to less than 150 °C within 6 seconds. Typical dwell time is 4 seconds at 250 °C.

A mildly-activated flux will eliminate the need for removal of corrosive residues in most applications.

REPAIRING SOLDERED JOINTS

Fix the component by first soldering two diagonally-opposite end leads. Use only a low voltage soldering iron (less than 24 V) applied to the flat part of the lead. Contact time must be limited to 10 seconds at up to 300 °C. When using a dedicated tool, all other leads can be soldered in one operation within 2 to 5 seconds between 270 and 320 °C.

Infrared remote control decoder

SAA3049A

DEFINITIONS

Data sheet status	
Objective specification	This data sheet contains target or goal specifications for product development.
Preliminary specification	This data sheet contains preliminary data; supplementary data may be published later.
Product specification	This data sheet contains final product specifications.
Limiting values	
Limiting values given are in accordance with the Absolute Maximum Rating System (IEC 134). Stress above one or more of the limiting values may cause permanent damage to the device. These are stress ratings only and operation of the device at these or at any other conditions above those given in the Characteristics sections of the specification is not implied. Exposure to limiting values for extended periods may affect device reliability.	
Application information	
Where application information is given, it is advisory and does not form part of the specification.	

LIFE SUPPORT APPLICATIONS

These products are not designed for use in life support appliances, devices, or systems where malfunction of these products can reasonably be expected to result in personal injury. Philips customers using or selling these products for use in such applications do so at their own risk and agree to fully indemnify Philips for any damages resulting from such improper use or sale.

Infrared remote control decoder

SAA3049A

NOTES

Philips Semiconductors – a worldwide company

Argentina: see South America

Australia: 34 Waterloo Road, NORTH RYDE, NSW 2113,
Tel. +61 2 9805 4455, Fax. +61 2 9805 4466

Austria: Computerstr. 6, A-1101 WIEN, P.O. Box 213,
Tel. +43 1 60 101, Fax. +43 1 60 101 1210

Belarus: Hotel Minsk Business Center, Bld. 3, r. 1211, Volodarski Str. 6,
220050 MINSK, Tel. +375 172 200 733, Fax. +375 172 200 773

Belgium: see The Netherlands

Brazil: see South America

Bulgaria: Philips Bulgaria Ltd., Energoproject, 15th floor,
51 James Bourchier Blvd., 1407 SOFIA,
Tel. +359 2 689 211, Fax. +359 2 689 102

Canada: PHILIPS SEMICONDUCTORS/COMPONENTS,
Tel. +1 800 234 7381

China/Hong Kong: 501 Hong Kong Industrial Technology Centre,
72 Tat Chee Avenue, Kowloon Tong, HONG KONG,
Tel. +852 2319 7888, Fax. +852 2319 7700

Colombia: see South America

Czech Republic: see Austria

Denmark: Prags Boulevard 80, PB 1919, DK-2300 COPENHAGEN S,
Tel. +45 32 88 2636, Fax. +45 31 57 1949

Finland: Sinikalliontie 3, FIN-02630 ESPOO,
Tel. +358 615 800, Fax. +358 615 80920

France: 4 Rue du Port-aux-Vins, BP317, 92156 SURESNES Cedex,
Tel. +33 1 40 99 6161, Fax. +33 1 40 99 6427

Germany: Hammerbrookstraße 69, D-20097 HAMBURG,
Tel. +49 40 23 53 60, Fax. +49 40 23 536 300

Greece: No. 15, 25th March Street, GR 17778 TAVROS,
Tel. +30 1 4894 339/911, Fax. +30 1 4814 240

Hungary: see Austria

India: Philips INDIA Ltd, Shivsagar Estate, A Block, Dr. Annie Besant Rd.
Worli, MUMBAI 400 018, Tel. +91 22 4938 541, Fax. +91 22 4938 722

Indonesia: see Singapore

Ireland: Newstead, Clonskeagh, DUBLIN 14,
Tel. +353 1 7640 000, Fax. +353 1 7640 200

Israel: RAPAC Electronics, 7 Kehilat Saloniki St, TEL AVIV 61180,
Tel. +972 3 645 0444, Fax. +972 3 649 1007

Italy: PHILIPS SEMICONDUCTORS, Piazza IV Novembre 3,
20124 MILANO, Tel. +39 2 6752 2531, Fax. +39 2 6752 2557

Japan: Philips Bldg 13-37, Kohnan 2-chome, Minato-ku, TOKYO 108,
Tel. +81 3 3740 5130, Fax. +81 3 3740 5077

Korea: Philips House, 260-199 Itaewon-dong, Yongsan-ku, SEOUL,
Tel. +82 2 709 1412, Fax. +82 2 709 1415

Malaysia: No. 76 Jalan Universiti, 46200 PETALING JAYA, SELANGOR,
Tel. +60 3 750 5214, Fax. +60 3 757 4880

Mexico: 5900 Gateway East, Suite 200, EL PASO, TEXAS 79905,
Tel. +9-5 800 234 7381

Middle East: see Italy

Netherlands: Postbus 90050, 5600 PB EINDHOVEN, Bldg. VB,
Tel. +31 40 27 82785, Fax. +31 40 27 88399

New Zealand: 2 Wagener Place, C.P.O. Box 1041, AUCKLAND,
Tel. +64 9 849 4160, Fax. +64 9 849 7811

Norway: Box 1, Manglerud 0612, OSLO,
Tel. +47 22 74 8000, Fax. +47 22 74 8341

Philippines: Philips Semiconductors Philippines Inc.,
106 Valero St. Salcedo Village, P.O. Box 2108 MCC, MAKATI,
Metro MANILA, Tel. +63 2 816 6380, Fax. +63 2 817 3474

Poland: Ul. Lukiska 10, PL 04-123 WARSZAWA,
Tel. +48 22 612 2831, Fax. +48 22 612 2327

Portugal: see Spain

Romania: see Italy

Russia: Philips Russia, Ul. Usatcheva 35A, 119048 MOSCOW,
Tel. +7 095 926 5361, Fax. +7 095 564 8323

Singapore: Lorong 1, Toa Payoh, SINGAPORE 1231,
Tel. +65 350 2538, Fax. +65 251 6500

Slovakia: see Austria

Slovenia: see Italy

South Africa: S.A. PHILIPS Pty Ltd., 195-215 Main Road Martindale,
2092 JOHANNESBURG, P.O. Box 7430 Johannesburg 2000,
Tel. +27 11 470 5911, Fax. +27 11 470 5494

South America: Rua do Rocio 220, 5th floor, Suite 51,
04552-903 São Paulo, SÃO PAULO - SP, Brazil,
Tel. +55 11 821 2333, Fax. +55 11 829 1849

Spain: Balmes 22, 08007 BARCELONA,
Tel. +34 3 301 6312, Fax. +34 3 301 4107

Sweden: Kottbygatan 7, Akalla, S-16485 STOCKHOLM,
Tel. +46 8 632 2000, Fax. +46 8 632 2745

Switzerland: Allmendstrasse 140, CH-8027 ZÜRICH,
Tel. +41 1 488 2686, Fax. +41 1 481 7730

Taiwan: PHILIPS TAIWAN Ltd., 23-30F, 66,
Chung Hsiao West Road, Sec. 1, P.O. Box 22978,
TAIPEI 100, Tel. +886 2 382 4443, Fax. +886 2 382 4444

Thailand: PHILIPS ELECTRONICS (THAILAND) Ltd.,
209/2 Sanpavuth-Bangna Road Prakanong, BANGKOK 10260,
Tel. +66 2 745 4090, Fax. +66 2 398 0793

Turkey: Talatpasa Cad. No. 5, 80640 GÜLTEPE/ISTANBUL,
Tel. +90 212 279 2770, Fax. +90 212 282 6707

Ukraine: PHILIPS UKRAINE, 4 Patrice Lumumba str., Building B, Floor 7,
252042 KIEV, Tel. +380 44 264 2776, Fax. +380 44 268 0461

United Kingdom: Philips Semiconductors Ltd., 276 Bath Road, Hayes,
MIDDLESEX UB3 5BX, Tel. +44 181 730 5000, Fax. +44 181 754 8421

United States: 811 East Arques Avenue, SUNNYVALE, CA 94088-3409,
Tel. +1 800 234 7381

Uruguay: see South America

Vietnam: see Singapore

Yugoslavia: PHILIPS, Trg N. Pasica 5/v, 11000 BEOGRAD,
Tel. +381 11 825 344, Fax. +381 11 635 777

For all other countries apply to: Philips Semiconductors, Marketing & Sales Communications,
Building BE-p, P.O. Box 218, 5600 MD EINDHOVEN, The Netherlands, Fax. +31 40 27 24825

Internet: <http://www.semiconductors.philips.com>

© Philips Electronics N.V. 1996

SCA51

All rights are reserved. Reproduction in whole or in part is prohibited without the prior written consent of the copyright owner.

The information presented in this document does not form part of any quotation or contract, is believed to be accurate and reliable and may be changed without notice. No liability will be accepted by the publisher for any consequence of its use. Publication thereof does not convey nor imply any license under patent- or other industrial or intellectual property rights.

Printed in The Netherlands

537021/25/02/pp16

Date of release: 1996 Sep 13

Document order number: 9397 750 01145

Let's make things better.

Philips
Semiconductors



PHILIPS

This datasheet has been download from:

www.datasheetcatalog.com

Datasheets for electronics components.